

Full Input Data And Results

User and Project Details

Project:	Land West of Park Farm
Title:	Butt Lane / Gloucester Road / Morton Way Mitigation
Location:	
Additional detail:	
File name:	004_Butt Ln_Glouc Rd_Morton Wy_v4 SK08G V2_School Trips_Ped 2nd Cycle.lsg3x
Author:	
Company:	Peter Brett Associates LLP
Address:	10 Queen Square, BS1 4NT

Network Layout Diagram

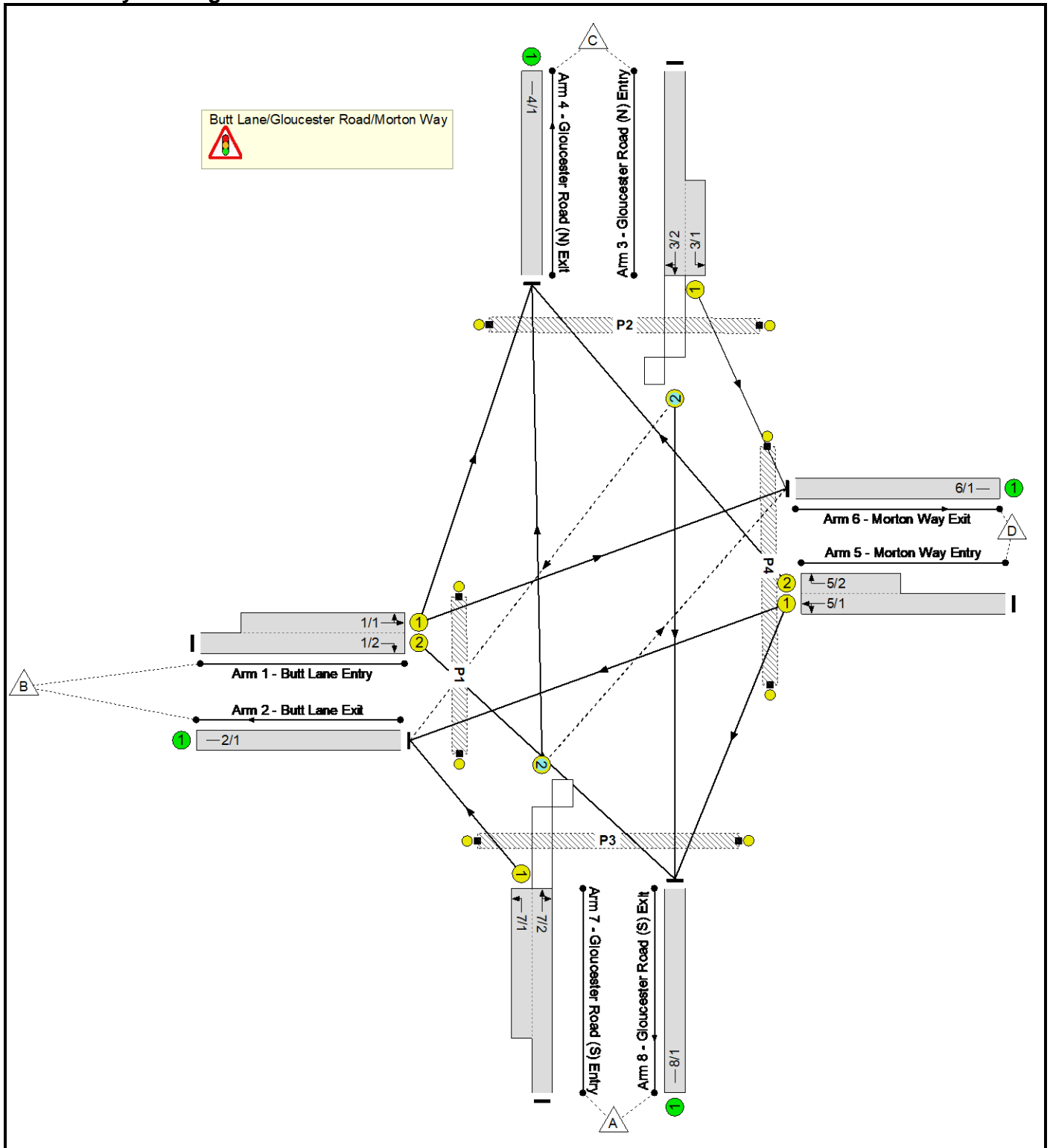

Scenario 1: '2028 Test + School Trips 8AM' (FG1: '2028 Test + School Trips 8AM', Plan 1: 'Network Control Plan 1')
Phase Diagram

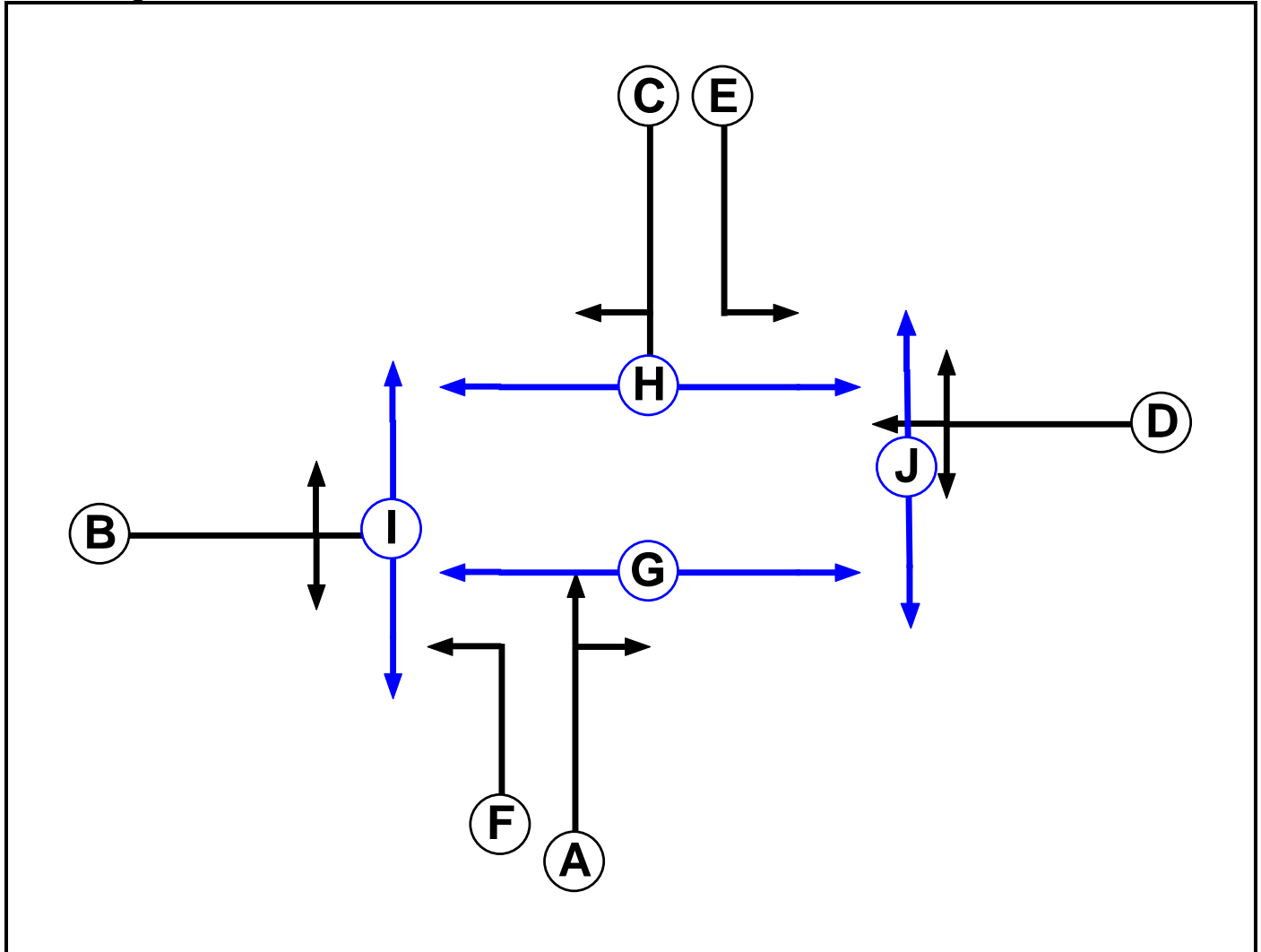

Phase Input Data

Phase Name	Phase Type	Stage Stream	Assoc. Phase	Street Min	Cont Min
A	Traffic	1		7	7
B	Traffic	1		7	7
C	Traffic	1		7	7
D	Traffic	1		7	7
E	Traffic	1		7	7
F	Traffic	1		7	7
G	Pedestrian	1		6	6
H	Pedestrian	1		6	6
I	Pedestrian	1		6	6
J	Pedestrian	1		6	6

Phase Intergrens Matrix

Terminating Phase	Starting Phase										
		A	B	C	D	E	F	G	H	I	J
	A		6	-	8	-	-	5	12	-	12
	B	5		8	7	8	-	9	11	5	11
	C	-	9		7	-	-	12	5	12	-
	D	7	7	5		-	8	11	9	11	5
	E	-	5	-	-		-	-	5	-	8
	F	-	-	-	5	-		5	-	7	-
	G	11	11	11	11	-	11		-	-	-
	H	11	11	11	11	11	-	-		-	-
	I	-	14	14	14	-	14	-	-		-
J	15	15	-	15	15	-	-	-	-		

Phases in Stage

Stream	Stage No.	Phases in Stage
1	1	A C E F
1	2	D E
1	3	B F
1	4	G H I J

Stage Diagram

Stage Stream: 1

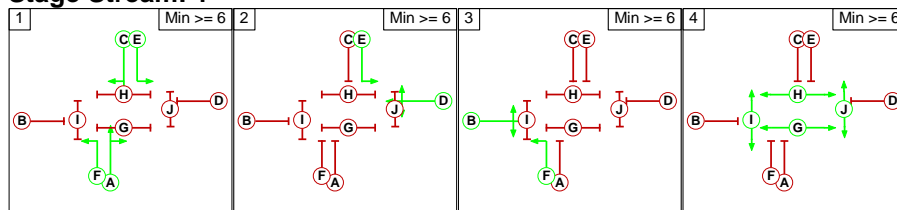

Phase Delays

Stage Stream: 1

Term. Stage	Start Stage	Phase	Type	Value	Cont value
1	2	A	Losing	1	1
1	2	C	Losing	2	2
1	2	F	Losing	4	4
1	3	A	Losing	3	3
1	3	E	Losing	4	4
2	3	E	Losing	2	2
3	4	F	Losing	4	4

Prohibited Stage Change

Stage Stream: 1

		To Stage			
		1	2	3	4
From Stage	1		9	9	12
	2	8		8	11
	3	8	8		11
	4	15	15	15	

Scenario 2: '2028 Test + School Trips 5PM' (FG2: '2028 Test + School Trips 5PM', Plan 1: 'Network Control Plan 1')

Phase Diagram

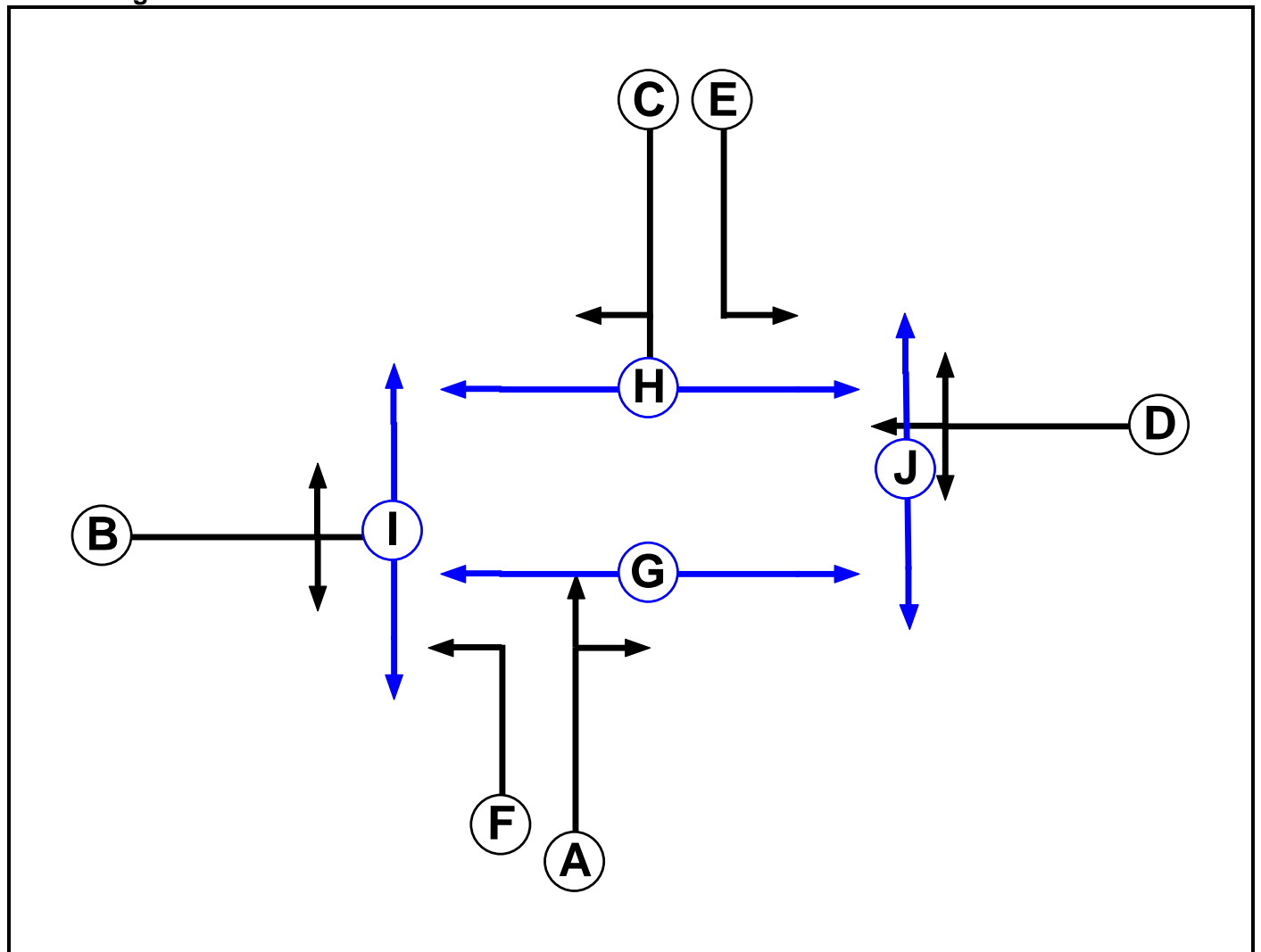

Phase Input Data

Phase Name	Phase Type	Stage Stream	Assoc. Phase	Street Min	Cont Min
A	Traffic	1		7	7
B	Traffic	1		7	7
C	Traffic	1		7	7
D	Traffic	1		7	7
E	Traffic	1		7	7
F	Traffic	1		7	7
G	Pedestrian	1		6	6
H	Pedestrian	1		6	6
I	Pedestrian	1		6	6
J	Pedestrian	1		6	6

Phase Intergreens Matrix

		Starting Phase									
		A	B	C	D	E	F	G	H	I	J
Terminating Phase	A		6	-	8	-	-	5	12	-	12
	B	5		8	7	8	-	9	11	5	11
	C	-	9		7	-	-	12	5	12	-
	D	7	7	5		-	8	11	9	11	5
	E	-	5	-	-		-	-	5	-	8
	F	-	-	-	5	-		5	-	7	-
	G	11	11	11	11	-	11		-	-	-
	H	11	11	11	11	11	-	-		-	-
	I	-	14	14	14	-	14	-	-		-
	J	15	15	-	15	15	-	-	-	-	

Phases in Stage

Stream	Stage No.	Phases in Stage
1	1	A C E F
1	2	D E
1	3	B F
1	4	G H I J

Stage Diagram

Stage Stream: 1

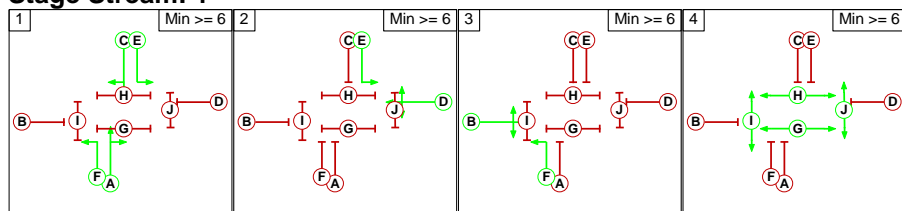

Full Input Data And Results

Phase Delays

Stage Stream: 1

Term. Stage	Start Stage	Phase	Type	Value	Cont value
1	2	A	Losing	1	1
1	2	C	Losing	2	2
1	2	F	Losing	4	4
1	3	A	Losing	3	3
1	3	E	Losing	4	4
2	3	E	Losing	2	2
3	4	F	Losing	4	4

Prohibited Stage Change

Stage Stream: 1

From Stage	To Stage			
	1	2	3	4
1	9	9	9	12
2	8	8	8	11
3	8	8	8	11
4	15	15	15	15

Full Input Data And Results

Give-Way Lane Input Data

Junction: Butt Lane/Gloucester Road/Morton Way											
Lane	Movement	Max Flow when Giving Way (PCU/Hr)	Min Flow when Giving Way (PCU/Hr)	Opposing Lane	Opp. Lane Coeff.	Opp. Mvmnts.	Right Turn Storage (PCU)	Non-Blocking Storage (PCU)	RTF	Right Turn Move up (s)	Max Turns in Intergreen (PCU)
3/2 (Gloucester Road (N) Entry)	2/1 (Right)	1439	0	7/2	1.09	To 4/1 (Ahead)	8.00	2.00	0.50	8	2.00
				7/1	1.09	All					
7/2 (Gloucester Road (S) Entry)	6/1 (Right)	1439	0	3/2	1.09	To 8/1 (Ahead)	8.00	2.00	0.50	8	2.00
				3/1	1.09	All					

Full Input Data And Results

Lane Input Data

Junction: Butt Lane/Gloucester Road/Morton Way												
Lane	Lane Type	Phases	Start Disp.	End Disp.	Physical Length (PCU)	Sat Flow Type	Def User Saturation Flow (PCU/Hr)	Lane Width (m)	Gradient	Nearside Lane	Turns	Turning Radius (m)
1/1 (Butt Lane Entry)	U	B	2	3	20.5	Geom	-	3.00	0.00	Y	Arm 4 Left	10.00
											Arm 6 Ahead	19.00
1/2 (Butt Lane Entry)	U	B	2	3	60.0	Geom	-	3.00	0.00	Y	Arm 8 Right	10.00
2/1 (Butt Lane Exit)	U		2	3	60.0	Inf	-	-	-	-	-	-
3/1 (Gloucester Road (N) Entry)	U	E	2	3	7.0	Geom	-	3.00	0.00	Y	Arm 6 Left	14.00
3/2 (Gloucester Road (N) Entry)	O	C	2	3	60.0	Geom	-	3.25	0.00	Y	Arm 2 Right	10.00
											Arm 8 Ahead	Inf
4/1 (Gloucester Road (N) Exit)	U		2	3	60.0	Inf	-	-	-	-	-	-
5/1 (Morton Way Entry)	U	D	2	3	60.0	Geom	-	3.25	0.00	Y	Arm 2 Ahead	19.00
											Arm 8 Left	10.00
5/2 (Morton Way Entry)	U	D	2	3	7.3	Geom	-	3.25	0.00	N	Arm 4 Right	10.00
6/1 (Morton Way Exit)	U		2	3	60.0	Inf	-	-	-	-	-	-
7/1 (Gloucester Road (S) Entry)	U	F	2	3	11.0	Geom	-	3.00	0.00	Y	Arm 2 Left	12.00
7/2 (Gloucester Road (S) Entry)	O	A	2	3	60.0	Geom	-	3.25	0.00	Y	Arm 4 Ahead	Inf
											Arm 6 Right	10.00
8/1 (Gloucester Road (S) Exit)	U		2	3	60.0	Inf	-	-	-	-	-	-

Traffic Flow Groups

Flow Group	Start Time	End Time	Duration	Formula
1: '2028 Test + School Trips 8AM'	08:00	09:00	01:00	
2: '2028 Test + School Trips 5PM'	17:00	18:00	01:00	

Full Input Data And Results

Scenario 1: '2028 Test + School Trips 8AM' (FG1: '2028 Test + School Trips 8AM', Plan 1: 'Network Control Plan 1')

Traffic Flows, Desired

Desired Flow :

		Destination				
		A	B	C	D	Tot.
Origin	A	0	161	146	92	399
	B	300	0	202	427	929
	C	256	118	0	90	464
	D	161	203	85	0	449
	Tot.	717	482	433	609	2241

Traffic Lane Flows

Lane	Scenario 1: 2028 Test + School Trips 8AM
Junction: Butt Lane/Gloucester Road/Morton Way	
1/1 (short)	629
1/2 (with short)	929(In) 300(Out)
2/1	482
3/1 (short)	90
3/2 (with short)	464(In) 374(Out)
4/1	433
5/1 (with short)	449(In) 364(Out)
5/2 (short)	85
6/1	609
7/1 (short)	161
7/2 (with short)	399(In) 238(Out)
8/1	717

Lane Saturation Flows

Junction: Butt Lane/Gloucester Road/Morton Way								
Lane	Lane Width (m)	Gradient	Nearside Lane	Allowed Turns	Turning Radius (m)	Turning Prop.	Sat Flow (PCU/Hr)	Flared Sat Flow (PCU/Hr)
1/1 (Butt Lane Entry)	3.00	0.00	Y	Arm 4 Left	10.00	32.1 %	1738	1738
				Arm 6 Ahead	19.00	67.9 %		
1/2 (Butt Lane Entry)	3.00	0.00	Y	Arm 8 Right	10.00	100.0 %	1665	1665
2/1 (Butt Lane Exit Lane 1)	Infinite Saturation Flow						Inf	Inf
3/1 (Gloucester Road (N) Entry)	3.00	0.00	Y	Arm 6 Left	14.00	100.0 %	1730	1730
3/2 (Gloucester Road (N) Entry)	3.25	0.00	Y	Arm 2 Right	10.00	31.6 %	1852	1852
				Arm 8 Ahead	Inf	68.4 %		
4/1 (Gloucester Road (N) Exit Lane 1)	Infinite Saturation Flow						Inf	Inf
5/1 (Morton Way Entry)	3.25	0.00	Y	Arm 2 Ahead	19.00	55.8 %	1747	1747
				Arm 8 Left	10.00	44.2 %		
5/2 (Morton Way Entry)	3.25	0.00	N	Arm 4 Right	10.00	100.0 %	1809	1809
6/1 (Morton Way Exit Lane 1)	Infinite Saturation Flow						Inf	Inf
7/1 (Gloucester Road (S) Entry)	3.00	0.00	Y	Arm 2 Left	12.00	100.0 %	1702	1702
7/2 (Gloucester Road (S) Entry)	3.25	0.00	Y	Arm 4 Ahead	Inf	61.3 %	1834	1834
				Arm 6 Right	10.00	38.7 %		
8/1 (Gloucester Road (S) Exit Lane 1)	Infinite Saturation Flow						Inf	Inf

Scenario 2: '2028 Test + School Trips 5PM' (FG2: '2028 Test + School Trips 5PM', Plan 1: 'Network Control Plan 1')

Traffic Flows, Desired

Desired Flow :

	Destination					
	A	B	C	D	Tot.	
Origin	A	0	229	272	124	625
	B	172	0	91	207	470
	C	143	149	0	86	378
	D	95	341	97	0	533
	Tot.	410	719	460	417	2006

Full Input Data And Results

Traffic Lane Flows

Lane	Scenario 2: 2028 Test + School Trips 5PM
Junction: Butt Lane/Gloucester Road/Morton Way	
1/1 (short)	298
1/2 (with short)	470(In) 172(Out)
2/1	719
3/1 (short)	86
3/2 (with short)	378(In) 292(Out)
4/1	460
5/1 (with short)	533(In) 436(Out)
5/2 (short)	97
6/1	417
7/1 (short)	229
7/2 (with short)	625(In) 396(Out)
8/1	410

Lane Saturation Flows

Junction: Butt Lane/Gloucester Road/Morton Way								
Lane	Lane Width (m)	Gradient	Nearside Lane	Allowed Turns	Turning Radius (m)	Turning Prop.	Sat Flow (PCU/Hr)	Flared Sat Flow (PCU/Hr)
1/1 (Butt Lane Entry)	3.00	0.00	Y	Arm 4 Left	10.00	30.5 %	1740	1740
				Arm 6 Ahead	19.00	69.5 %		
1/2 (Butt Lane Entry)	3.00	0.00	Y	Arm 8 Right	10.00	100.0 %	1665	1665
2/1 (Butt Lane Exit Lane 1)	Infinite Saturation Flow						Inf	Inf
3/1 (Gloucester Road (N) Entry)	3.00	0.00	Y	Arm 6 Left	14.00	100.0 %	1730	1730
3/2 (Gloucester Road (N) Entry)	3.25	0.00	Y	Arm 2 Right	10.00	51.0 %	1802	1802
				Arm 8 Ahead	Inf	49.0 %		
4/1 (Gloucester Road (N) Exit Lane 1)	Infinite Saturation Flow						Inf	Inf
5/1 (Morton Way Entry)	3.25	0.00	Y	Arm 2 Ahead	19.00	78.2 %	1773	1773
				Arm 8 Left	10.00	21.8 %		
5/2 (Morton Way Entry)	3.25	0.00	N	Arm 4 Right	10.00	100.0 %	1809	1809
6/1 (Morton Way Exit Lane 1)	Infinite Saturation Flow						Inf	Inf
7/1 (Gloucester Road (S) Entry)	3.00	0.00	Y	Arm 2 Left	12.00	100.0 %	1702	1702
7/2 (Gloucester Road (S) Entry)	3.25	0.00	Y	Arm 4 Ahead	Inf	68.7 %	1853	1853
				Arm 6 Right	10.00	31.3 %		
8/1 (Gloucester Road (S) Exit Lane 1)	Infinite Saturation Flow						Inf	Inf

Scenario 1: '2028 Test + School Trips 8AM' (FG1: '2028 Test + School Trips 8AM', Plan 1: 'Network Control Plan 1')

Stage Sequence Diagram

Stage Stream: 1

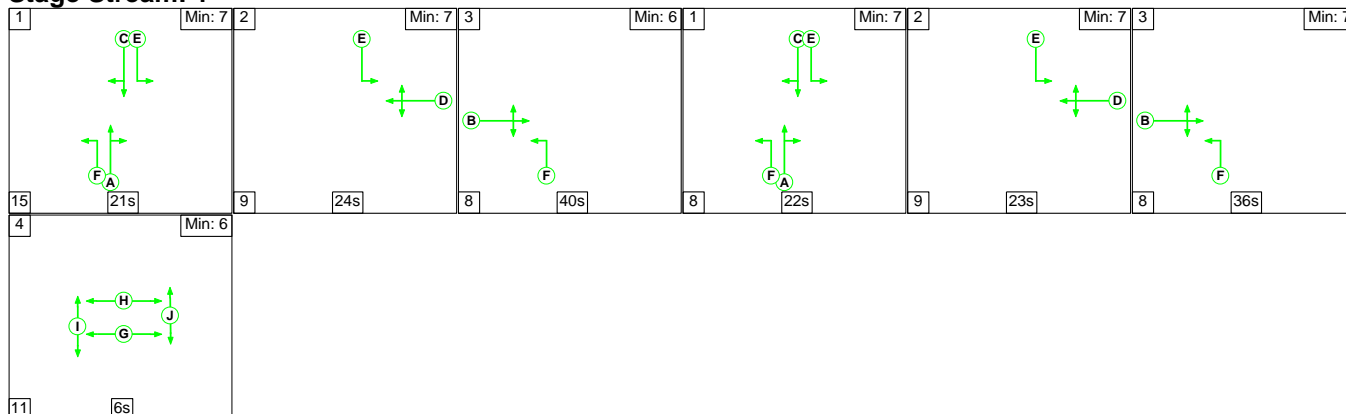

Full Input Data And Results

Stage Timings

Stage Stream: 1

Stage	1	2	3	1	2	3	4
Duration	21	24	40	22	23	36	6
Change Point	0	36	69	117	147	179	223

Signal Timings Diagram

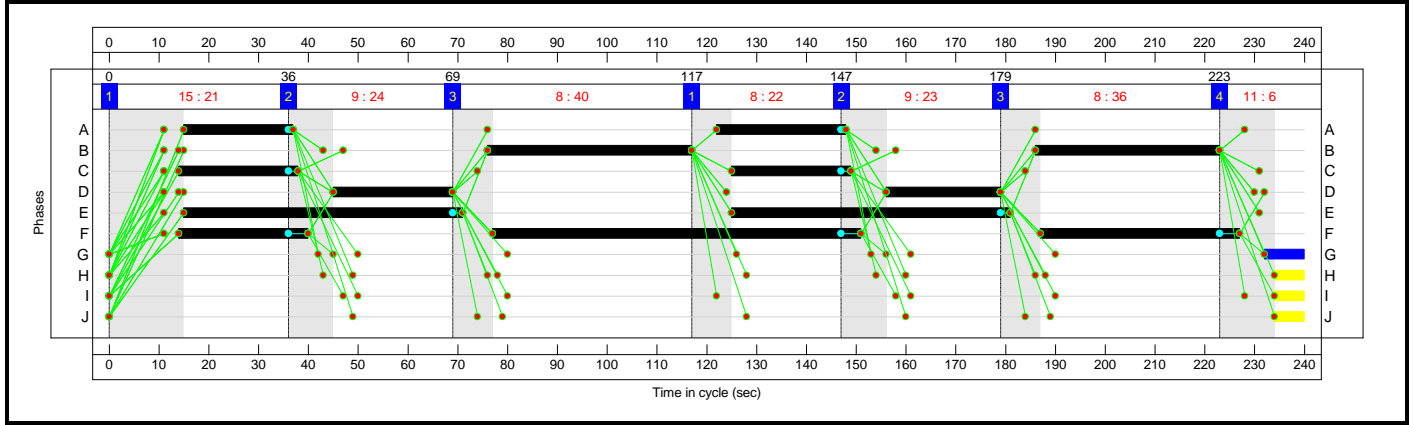

Full Input Data And Results
Network Layout Diagram

Full Input Data And Results

Butt Lane/Gloucester Road/Morton Way
 PRC: -20.6 %
 Total Traffic Delay: 125.6 pcuHr
 Ave. Route Delay Per Ped: 0.0 s/Ped

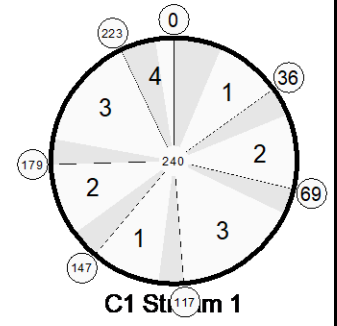
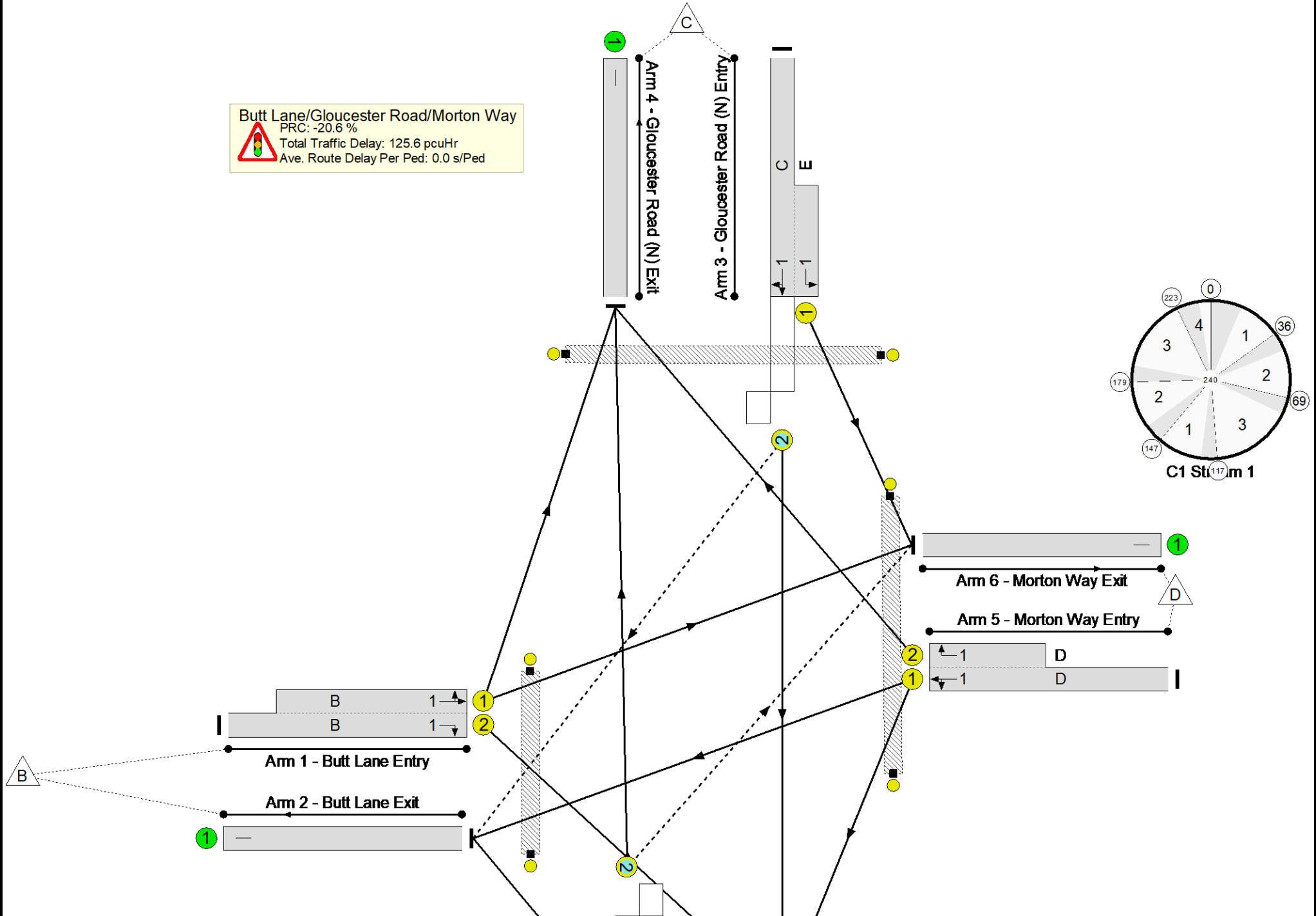

Full Input Data And Results

Network Results

Item	Lane Description	Lane Type	Controller Stream	Position In Filtered Route	Full Phase	Arrow Phase	Num Greens	Total Green (s)	Arrow Green (s)	Demand Flow (pcu)	Sat Flow (pcu/Hr)	Capacity (pcu)	Deg Sat (%)
Network: Butt Lane / Gloucester Road / Morton Way Mitigaion	-	-	N/A	-	-		-	-	-	-	-	-	108.6%
Butt Lane/Gloucester Road/Morton Way	-	-	N/A	-	-		-	-	-	-	-	-	108.6%
1/2+1/1	Butt Lane Entry Left Ahead Right	U	1	N/A	B		2	78	-	929	1665:1738	276+579	108.6 : 108.6%
2/1	Butt Lane Exit	U	N/A	N/A	-		-	-	-	482	Inf	Inf	0.0%
3/2+3/1	Gloucester Road (N) Entry Right Left Ahead	O+U	1	N/A	C E		2	48:112	-	464	1852:1730	345+83	108.4 : 108.4%
4/1	Gloucester Road (N) Exit	U	N/A	N/A	-		-	-	-	433	Inf	Inf	0.0%
5/1+5/2	Morton Way Entry Ahead Right Left	U	1	N/A	D		2	47	-	449	1747:1809	341+80	106.9 : 106.9%
6/1	Morton Way Exit	U	N/A	N/A	-		-	-	-	609	Inf	Inf	0.0%
7/2+7/1	Gloucester Road (S) Entry Left Ahead Right	O+U	1	N/A	A F		2:3	48:140	-	399	1834:1702	357+241	66.8 : 66.8%
8/1	Gloucester Road (S) Exit	U	N/A	N/A	-		-	-	-	717	Inf	Inf	0.0%
Ped Link: P1	Unnamed Ped Link	-	1	-	I		1	6	-	0	-	0	0.0%
Ped Link: P2	Unnamed Ped Link	-	1	-	H		1	6	-	0	-	0	0.0%
Ped Link: P3	Unnamed Ped Link	-	1	-	G		1	8	-	0	-	0	0.0%
Ped Link: P4	Unnamed Ped Link	-	1	-	J		1	6	-	0	-	0	0.0%

Full Input Data And Results

Item	Arriving (pcu)	Leaving (pcu)	Turners In Gaps (pcu)	Turners When Unopposed (pcu)	Turners In Intergreen (pcu)	Uniform Delay (pcuHr)	Rand + Oversat Delay (pcuHr)	Storage Area Uniform Delay (pcuHr)	Total Delay (pcuHr)	Av. Delay Per PCU (s/pcu)	Max. Back of Uniform Queue (pcu)	Rand + Oversat Queue (pcu)	Mean Max Queue (pcu)
Network: Butt Lane / Gloucester Road / Morton Way Mitigaiton	-	-	159	0	42	38.7	86.2	0.6	125.6	-	-	-	-
Butt Lane/Gloucester Road/Morton Way	-	-	159	0	42	38.7	86.2	0.6	125.6	-	-	-	-
1/2+1/1	929	856	-	-	-	16.9	42.2	-	59.1	228.9	35.4	42.2	77.6
2/1	460	460	-	-	-	0.0	0.0	-	0.0	0.0	0.0	0.0	0.0
3/2+3/1	464	435	86	0	23	9.4	23.0	0.1	32.5	252.4	19.0	23.0	42.0
4/1	412	412	-	-	-	0.0	0.0	-	0.0	0.0	0.0	0.0	0.0
5/1+5/2	449	420	-	-	-	9.3	20.0	-	29.3	234.6	17.3	20.0	37.3
6/1	575	575	-	-	-	0.0	0.0	-	0.0	0.0	0.0	0.0	0.0
7/2+7/1	399	399	73	0	19	3.2	1.0	0.5	4.7	42.7	8.0	1.0	9.0
8/1	663	663	-	-	-	0.0	0.0	-	0.0	0.0	0.0	0.0	0.0
Ped Link: P1	0	0	-	-	-	-	-	-	-	-	-	-	-
Ped Link: P2	0	0	-	-	-	-	-	-	-	-	-	-	-
Ped Link: P3	0	0	-	-	-	-	-	-	-	-	-	-	-
Ped Link: P4	0	0	-	-	-	-	-	-	-	-	-	-	-
C1 Stream: 1 PRC for Signalled Lanes (%): -20.6 Total Delay for Signalled Lanes (pcuHr): 125.58 Cycle Time (s): 240 PRC Over All Lanes (%): -20.6 Total Delay Over All Lanes(pcuHr): 125.58													

Full Input Data And Results

Scenario 2: '2028 Test + School Trips 5PM' (FG2: '2028 Test + School Trips 5PM', Plan 1: 'Network Control Plan 1')

Stage Sequence Diagram

Stage Stream: 1

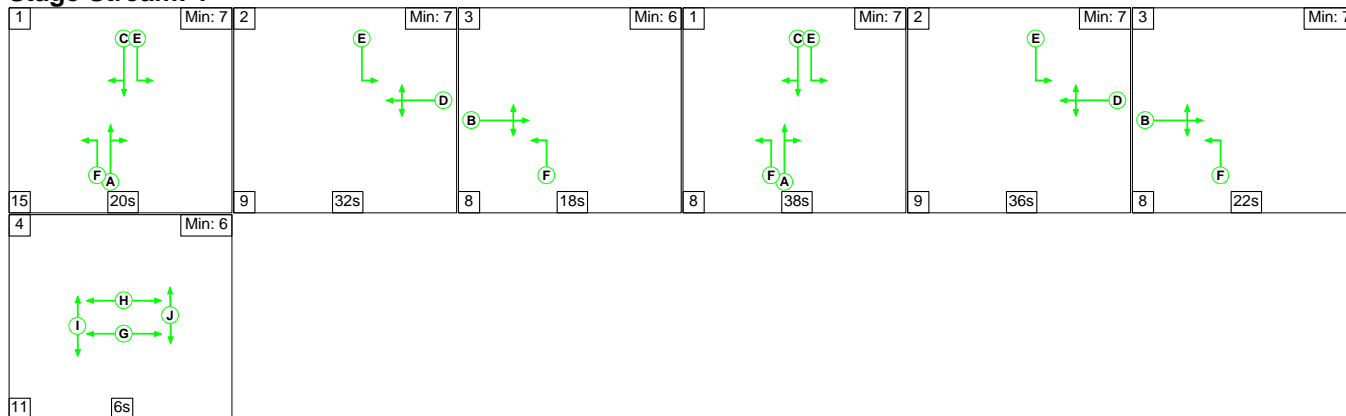

Stage Timings

Stage Stream: 1

Stage	1	2	3	1	2	3	4
Duration	20	32	18	38	36	22	6
Change Point	0	35	76	102	148	193	223

Signal Timings Diagram

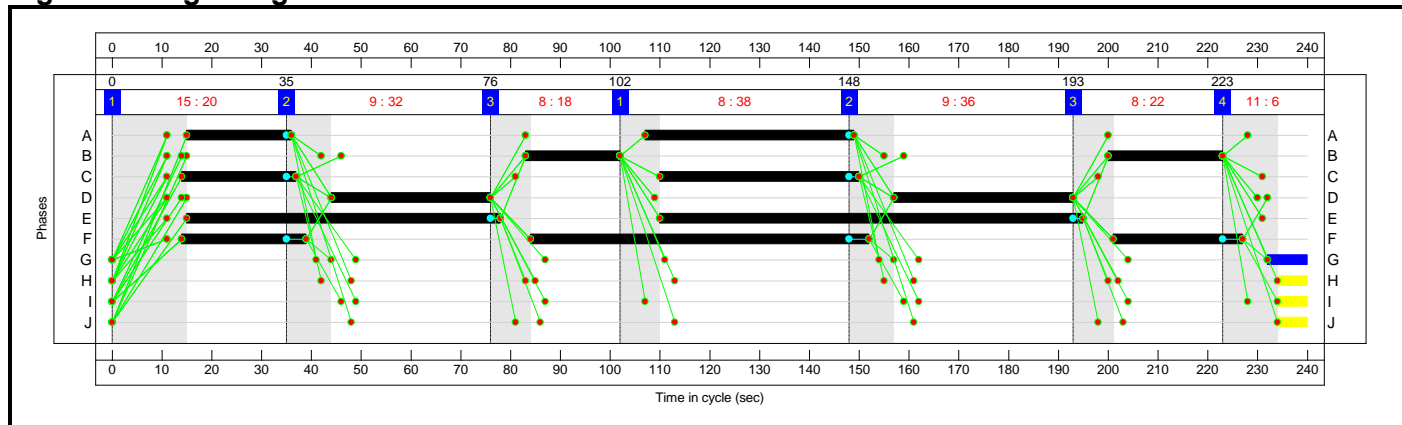

Full Input Data And Results
Network Layout Diagram

Full Input Data And Results

Butt Lane/Gloucester Road/Morton Way
 PRC: -3.8 %
 Total Traffic Delay: 42.8 pcuHr
 Ave. Route Delay Per Ped: 0.0 s/Ped

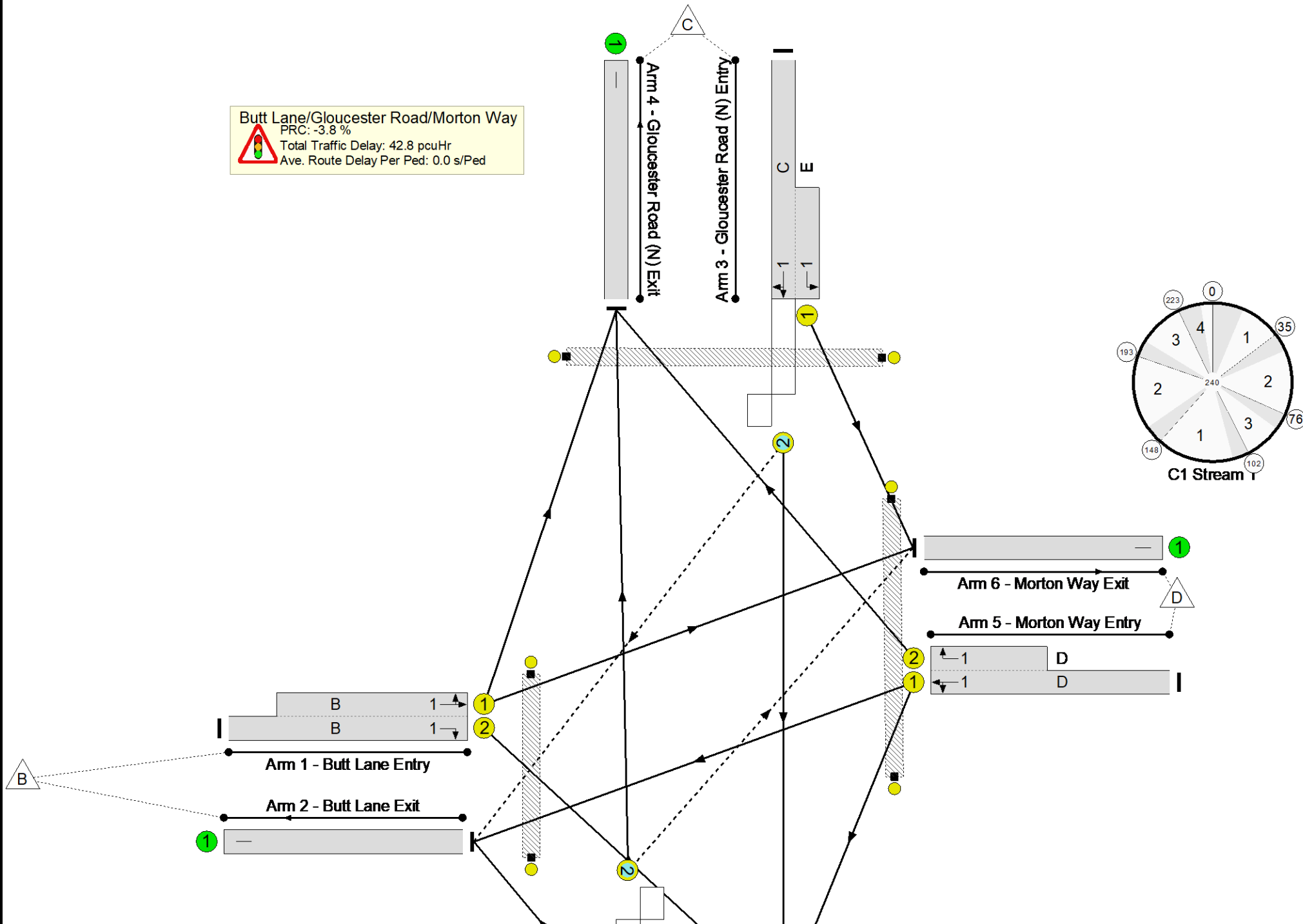

Full Input Data And Results

Network Results

Item	Lane Description	Lane Type	Controller Stream	Position In Filtered Route	Full Phase	Arrow Phase	Num Greens	Total Green (s)	Arrow Green (s)	Demand Flow (pcu)	Sat Flow (pcu/Hr)	Capacity (pcu)	Deg Sat (%)
Network: Butt Lane / Gloucester Road / Morton Way Mitigaion	-	-	N/A	-	-		-	-	-	-	-	-	93.4%
Butt Lane/Gloucester Road/Morton Way	-	-	N/A	-	-		-	-	-	-	-	-	93.4%
1/2+1/1	Butt Lane Entry Left Ahead Right	U	1	N/A	B		2	42	-	470	1665:1740	184+319	93.4 : 93.4%
2/1	Butt Lane Exit	U	N/A	N/A	-		-	-	-	719	Inf	Inf	0.0%
3/2+3/1	Gloucester Road (N) Entry Right Left Ahead	O+U	1	N/A	C E		2	63:148	-	378	1802:1730	321+95	90.9 : 90.9%
4/1	Gloucester Road (N) Exit	U	N/A	N/A	-		-	-	-	460	Inf	Inf	0.0%
5/1+5/2	Morton Way Entry Ahead Right Left	U	1	N/A	D		2	68	-	533	1773:1809	471+105	92.7 : 92.7%
6/1	Morton Way Exit	U	N/A	N/A	-		-	-	-	417	Inf	Inf	0.0%
7/2+7/1	Gloucester Road (S) Entry Left Ahead Right	O+U	1	N/A	A F		2:3	63:119	-	625	1853:1702	439+254	90.2 : 90.2%
8/1	Gloucester Road (S) Exit	U	N/A	N/A	-		-	-	-	410	Inf	Inf	0.0%
Ped Link: P1	Unnamed Ped Link	-	1	-	I		1	6	-	0	-	0	0.0%
Ped Link: P2	Unnamed Ped Link	-	1	-	H		1	6	-	0	-	0	0.0%
Ped Link: P3	Unnamed Ped Link	-	1	-	G		1	8	-	0	-	0	0.0%
Ped Link: P4	Unnamed Ped Link	-	1	-	J		1	6	-	0	-	0	0.0%

